



HAL
open science

Efficient Hybrid Algorithm Solution for Optimal Reactive Power Flow Using the Sensitive Bus Approach

Zahir Sahli, Abdellatif Hamouda, Samir Sayah, Damien Trentesaux,
Abdelghani Bekrar

► **To cite this version:**

Zahir Sahli, Abdellatif Hamouda, Samir Sayah, Damien Trentesaux, Abdelghani Bekrar. Efficient Hybrid Algorithm Solution for Optimal Reactive Power Flow Using the Sensitive Bus Approach. Engineering technology and Applied science research , 2022, 12 (1), pp.8210-8216. 10.48084/etasr.4680 . hal-03586802

HAL Id: hal-03586802

<https://uphf.hal.science/hal-03586802v1>

Submitted on 24 Feb 2022

HAL is a multi-disciplinary open access archive for the deposit and dissemination of scientific research documents, whether they are published or not. The documents may come from teaching and research institutions in France or abroad, or from public or private research centers.

L'archive ouverte pluridisciplinaire **HAL**, est destinée au dépôt et à la diffusion de documents scientifiques de niveau recherche, publiés ou non, émanant des établissements d'enseignement et de recherche français ou étrangers, des laboratoires publics ou privés.

Efficient Hybrid Algorithm Solution for Optimal Reactive Power Flow Using the Sensitive Bus Approach

Zahir Sahli

QUERE Laboratory
Electrical Engineering Department
University Ferhat Abbas Setif 1
Setif, Algeria
sah_zah@yahoo.fr

Samir Sayah

QUERE Laboratory
Electrical Engineering Department
University Ferhat Abbas Setif 1
Setif, Algeria
samir.sayah@univ-setif.dz

Abdellatif Hamouda

QUERE Laboratory
Optics and Fine Mechanics Institute
University Ferhat Abbas Setif 1
Setif, Algeria
a_hamouda1@yahoo.fr

Damien Trentesaux

LAMIH-UMR CNRS
University of Valenciennes
Valenciennes, France
damien.trentesaux@univ-valenciennes.fr

Abdelghani Bekrar

LAMIH-UMR CNRS
University of Valenciennes
Valenciennes, France
abdelghani.bekrar@univ-valenciennes.fr

Abstract-This paper presents the design and application of an efficient hybrid algorithm for solving the Optimal Reactive Power Flow (ORPF) problem. The ORPF is formulated as a nonlinear constrained optimization problem where the active power losses must be minimized. The proposed approach is based on the hybridization of Particle Swarm Optimization (PSO) and Tabu-Search (TS) technique. The proposed PSO-TS approach is used to find the settings of the control variables (i.e. generation bus voltages, transformer taps, and shunt capacitor sizes) which minimize transmission active power losses. The bus locations of the shunt capacitors are identified according to sensitive buses. To show the effectiveness of the proposed method, it is applied to the IEEE 30 bus benchmark test system and is compared with PSO and TS without hybridization, along with some other published approaches. The obtained results reveal the effectiveness of the proposed method in dealing with the highly nonlinear constrained nature of the ORPF problem.

Keywords-optimal reactive power flow; active power loss minimization; hybrid methods; particle swarm optimization; tabu search; sensitive bus

I. INTRODUCTION

Due to their complex construction and operation, electrical power networks encounter several challenges. In modern power

system operation and planning, Optimal Reactive Power Flow (ORPF), which is a specific Optimal Power Flow (OPF) and a highly constrained large-scale non-linear optimization problem, has emerged as one of the major problems and intensively explored topics. The goal of ORPF is to find the optimal settings for a power system under some imposed equality and inequality constraints, in order to optimize its active power loss objective [1, 2].

The objective of ORPF in power systems is to minimize real power losses while satisfying a given set of operating and physical constraints. The ORPF then provides optimal control variables settings such as generator bus voltages, output of static reactive power compensators, transformer tap-settings, shunt capacitors, etc. [3, 4]. Due to its influence on the secure and economic operation of power systems, ORPF has attracted increasing interest from electric power suppliers. Many classical approaches for solving the ORPF problem have been reported such as the gradient based approach [5, 6], linear programming [7], non-linear programming [8, 9], quadratic programming [10], and interior point [11]. However, these methods have some disadvantages in solving complex ORPF problems, namely premature convergence, algorithmic complexity, and the local minima entrapment [12]. In order to overcome these drawbacks, researchers have applied

evolutionary and meta-heuristic algorithms such as the Genetic Algorithm (GA) [13], Differential Evolution (DE) [14], Artificial Physics Optimization (APO) [15], Sunflower Optimization (SFO) [16], Evolutionary Programming (EP) [17], Stud Krill Herd Algorithm (SKHA) [18], Whale Optimization Algorithm (WOA) [19] and Particle Swarm Optimization (PSO) [20, 21]. PSO in particular has received increased attention from researchers because of its searching capability. It was developed through simulations of a simplified social system, and has been found to be robust in solving continuous non-linear optimization problems. Generally, PSO has a more effective global searching ability at the beginning of the run and a local search near the end of the run [1]. PSO can generate high-quality solutions and has a more stable convergence than other stochastic methods. However, when solving complex multimodal problems, PSO can be trapped in local optima [22]. To overcome this drawback, PSO performance can be enhanced with a few adjustments. Hybridization is one of these modifications or techniques which, is applied to evolutionary algorithms in order to increase their efficiency and robustness [23].

Hybrid PSO has provided promising results for problems such as the power loss minimization problem [24, 25]. The novelty of this paper is that an efficient hybrid PSO with Tabu Search (PSO-TS) method is implemented to solve the ORPF problem by minimizing active power losses. The optimal locations of shunt capacitors have been identified based on sensitive buses.

To demonstrate the superiority of the proposed technique, the obtained results were compared to those given by standalone PSO and TS and some other published approaches. Simulations were performed with MATLAB using the IEEE 30-Bus benchmark system.

II. ORPF PROBLEM FORMULATION

The purpose of ORPF in a power system is to find the optimal settings of the reactive power control variables, which mainly include the generator voltages (V_G), the transformer tap-settings (T), and the shunt capacitors/reactors (Q_{sh}), to minimize the real power loss (P_{Loss}) while satisfying a given set of constraints. These comprise the power flow equations, the upper and lower limits of the control variables and the dependent variables, including mainly the PQ-bus voltages (V_{PQ}) and the reactive power out-puts of generators (Q_G). The ORPF mathematical model can be written as [14]:

$$\begin{cases} \min J(x,u) \text{ subject to} \\ g(x,u) = 0 \\ h(x,u) \leq 0 \end{cases} \quad (1)$$

where $J(x,u)$ represents the transmission active power losses, g and h are the sets of equality and inequality constraints respectively, x is the state or dependent variables vector, and u is the control or independent variables vector.

In this study, all control variables have been considered as continuous variables. The objective to be minimized is the system transmission active power losses. This objective function is expressed as [1]:

$$J(x,u) = \sum_{k=1}^{N_L} g_k (V_i^2 + V_j^2 - 2V_i V_j \cos \theta_{ij}) \quad (2)$$

where N_L is the number of transmission lines, V_i and V_j represent the voltage magnitude at buses i and j respectively, g_k is the conductance of branch k between buses i and j , and θ_{ij} is the voltage angle difference between bus i and bus j .

The elements of the state variables vector x are load bus voltage (V_L), generators' reactive power output (Q_G), and lines' apparent power flow (S_L). The control variables vector u includes the generation buses voltage (V_G), the transformer tap settings (T), and the shunt VAR compensators (Q_C). Accordingly, the x vector can be written as:

$$x^T = [V_{L_1} \dots V_{LN_{PQ}}, Q_{G_1} \dots Q_{GN_G}, S_{L_1} \dots S_{LN_L}] \quad (3)$$

where N_G is the number of generators, N_{PQ} is the number of PQ buses (load buses). u can be expressed as:

$$u^T = [V_{G_1} \dots V_{GN_G}, T_1 \dots T_{N_T}, Q_{C_1} \dots Q_{CN_C}] \quad (4)$$

where N_T is the number of tap regulating transformers and N_C is the number of shunt VAR compensation.

The minimization of the above function is subject to a number of equality and inequality constraints [1] which will be detailed below:

A. Equality Constrains

These constraints reflect the physical laws governing the electrical system, known as power flow equations. They are the expression of the balance between load demand (power loss included) and generated power. The power flow equations are:

$$P_{Gi} - P_{Di} - V_i \sum_{j=1}^{N_B} V_j (G_{ij} \cos \theta_{ij} + B_{ij} \sin \theta_{ij}) = 0 \quad (5)$$

$$Q_{Gi} - Q_{Di} - V_i \sum_{j=1}^{N_B} V_j (G_{ij} \sin \theta_{ij} - B_{ij} \cos \theta_{ij}) = 0 \quad (6)$$

where P_{Gi} , Q_{Gi} are the active and reactive power of the i^{th} generator, P_{Di} , Q_{Di} are the active and reactive power demand at bus i , N_B is the total number of buses, and B_{ij} , G_{ij} are the real and imaginary parts of the $(i,j)^{th}$ element of the bus admittance matrix.

B. Inequality Constraints

1) Inequality Constraints on Security Limits

Some limits are imposed for security purposes:

- Active power generated at the slack bus:

$$P_{G,slack}^{min} \leq P_{G,slack} \leq P_{G,slack}^{max} \quad (7)$$

- Load bus voltage:

$$V_{L_i}^{min} \leq V_{L_i} \leq V_{L_i}^{max} \quad i \in N_{PQ} \quad (8)$$

- Generated reactive power:

$$Q_{G_i}^{min} \leq Q_{G_i} \leq Q_{G_i}^{max} \quad i \in N_G \quad (9)$$

- Thermal limits: the apparent power flowing in line "L" must not exceed the maximum allowable apparent power flow value (S_L^{max}):

$$S_L \leq S_L^{max}, \quad L \in N_L \quad (10)$$

2) Inequality Constraints on Control Variable Limits

The different control variables are bounded as follows:

- Generator voltage limits:

$$V_{G_i}^{\min} \leq V_{G_i} \leq V_{G_i}^{\max} \quad i \in N_{PV} \quad (11)$$

- Transformer tap limits:

$$T_i^{\min} \leq T_i \leq T_i^{\max} \quad i \in N_T \quad (12)$$

- Shunt capacitor limits:

$$Q_{C_i}^{\min} \leq Q_{C_i} \leq Q_{C_i}^{\max} \quad i \in N_C \quad (13)$$

where $P_{G,slack}$ is the real power generation at the slack bus, V_{G_i} is the voltage magnitude at generator bus i , T_i is the tap ratio of the transformer i , Q_{C_i} is the reactive power compensation source at bus i , and N_{PQ} is the number of PQ bus. $(\cdot)^{\max}$ and $(\cdot)^{\min}$ are the upper and lower limits of the considered variables respectively.

The objective functions of equality and inequality constraints, are non-linear functions and they depend on control variables. Therefore, ORPF is a constrained non-linear optimization problem with multiple local minima [26]. The equality constraints given by (5) and (6) are met by solving the load-flow problem. The inequality constraints given by (11)-(13) should be maintained during the solution evolution, while (7)-(9) should be handled by additional techniques.

III. THE PROPOSED HYBRID ALGORITHM

Hybridization is a way of combining two techniques in a judicious manner, so that the resulting algorithm contains the positive features of both algorithms. The success of the meta-heuristic optimization algorithms depends to a large extent on the careful balance between the two conflicting goals: exploration (diversification) and exploitation (intensification). In order to achieve these two goals, the algorithms use local search techniques, global search approaches, or integrations of both, commonly known as hybrid methods [23]. For the ORPF problem, different hybridizations with PSO have been used to improve the algorithm's performance by avoiding premature convergence. For instance, PSO has been hybridized with the linear interior point method [27], fuzzy logic [28, 29], Pareto optimal set [30], Grey wolf technique [31], DE [32], multi-agent systems [1], imperialist competitive algorithm [33], GA [34], and chaotic bat algorithm [35]. Tabu search was used to solve OPF [36] and it is hybridized with harmony search algorithm to solve the reactive power flow problem [37]. Both algorithms (PSO, TS) and their hybridization (PSO-TS) for solving the ORPF problem are discussed below.

A. Particle Swarm Optimization

PSO is a population-based evolutionary computation technique. The main idea is to evolve the population (particles) of initial solutions in a search space in order to find the best solution. This evolution is an analogy of the behavior of some species as they look for food, like a flock of birds or a school of fish [38]. These particles move through the search domain with a specified velocity in search of the optimal solution. Each particle maintains a memory which helps it in keeping the track

of its previous best position. The positions of the particles are distinguished as personal best and global best. The swarm of particles evolves in the search space by modifying their velocities according to the following equations [23]:

$$v_i^{k+1} = w_i v_i^k + c_1 rand \times (pbest_i - x_i^k) + c_2 rand \times (gbest - x_i^k) \quad (14)$$

where v_i^k is the current velocity of particle i at iteration k , w_i is the inertia weight, $rand$ is a random number between 0 and 1, c_1 and c_2 are the acceleration coefficients, $pbest_i$ is the best position of the current particle achieved so far, $gbest$ is the global best position achieved by all informants, and x_i^k is the current position of particle i at iteration k .

The new position of each particle is given by:

$$x_i^{k+1} = x_i^k + v_i^{k+1} \quad (15)$$

The inertia weighting factor for the velocity of particle i is defined by the inertial weight approach [24]:

$$w_i = w_{max} - \frac{w_{max} - w_{min}}{iter_{max}} \times k \quad (16)$$

where $iter_{max}$ is the maximum number of iterations, k is the current iteration number, and w_{max} and w_{min} are the upper and lower limits of the inertia weighting factor.

The efficiency of PSO has been proved in a wide range of optimization problems. However, constrained non-linear optimization problems have not been widely studied with this method. The authors in [39] were the first to try to adapt PSO to constrained non-linear problems. The penalty function approach is used in this paper due to its simplicity of implementation and its proven efficiency for many constrained non-linear optimization problems. The ORPF objective function is then modified as follows [22]:

$$F_T = F + K_P (P_{G,slack} - P_{G,slack}^{lim})^2 + K_V \sum_{i=1}^{N_{PQ}} (V_{L_i} - V_{L_i}^{lim})^2 + K_Q \sum_{i=1}^{N_G} (Q_{G_i} - Q_{G_i}^{lim})^2 + K_S \sum_{i=1}^{N_L} (S_{L_i} - S_{L_i}^{lim})^2 \quad (17)$$

where F is the total active power loss given by (2), K_P , K_V , K_Q and K_S are the penalty factors of the slack bus generator, bus voltage limit violation, generator reactive power limit violation, and line flow violation respectively.

$P_{G,slack}^{lim}$, $V_{L_i}^{lim}$, $Q_{G_i}^{lim}$ and $S_{L_i}^{lim}$ are defined as follows:

$$P_{G,slack}^{lim} = \begin{cases} P_{G,slack}^{\min} & \text{if } P_{G,slack} < P_{G,slack}^{\min} \\ P_{G,slack}^{\max} & \text{if } P_{G,slack} > P_{G,slack}^{\max} \end{cases} \quad (18)$$

$$V_{L_i}^{lim} = \begin{cases} V_{L_i}^{\min} & \text{if } V_{L_i} < V_{L_i}^{\min} \\ V_{L_i}^{\max} & \text{if } V_{L_i} > V_{L_i}^{\max} \end{cases} \quad (19)$$

$$Q_{G_i}^{lim} = \begin{cases} Q_{G_i}^{\min} & \text{if } Q_{G_i} < Q_{G_i}^{\min} \\ Q_{G_i}^{\max} & \text{if } Q_{G_i} > Q_{G_i}^{\max} \end{cases} \quad (20)$$

$$S_{L_i}^{lim} = \begin{cases} S_{L_i}^{\max} & \text{if } S_{L_i} > S_{L_i}^{\max} \\ 0 & \text{if } S_{L_i} \leq S_{L_i}^{\max} \end{cases} \quad (21)$$

B. The Tabu Search Method

TS is a meta-heuristic proposed in 1986 that guides a local heuristic search procedure to explore the solution space beyond

local optimality. This technique uses an operation called "move" to define the neighborhood of any given solution. One of the main components of TS is its use of adaptive memory, which creates a more flexible search behavior [40]. The simplest of these processes consists in recording in a tabu list the features of the visited regions on the space search, which provides a means to avoid revisiting already inspected solutions and thus avoid becoming trapped in local optima.

C. The Hybrid PSO-TS Approach Applied to ORPF

Several arguments support the hybridization of PSO with TS. Firstly, PSO is a global population-based algorithm while TS proposes a fast local search mechanism. Secondly, the incorporation of TS into PSO enables the algorithm to maintain population diversity. Finally, TS is integrated to prevent PSO from falling into local optima. To this end, TS is proposed to serve as a local optimizer of the best local solutions (*pbest*). The *pbest* solutions of PSO are the inputs of the TS diversification procedure. For each solution *s*, a neighborhood list is defined. Candidate solutions from the list are examined and the best one becomes the new current solution that replaces *s*. The move leading to the solution *s* is saved in the tabu list, called *best_list*. This process is repeated to produce successive new solutions until a defined stopping criterion is satisfied. The neighborhoods of a solution *s* are defined by hyper-rectangles introduced in [41]. A hyper-rectangle of *s* with a radius *r* is the space containing solutions *s'* such that the distance between *s* and *s'* is less than *r*. To generate *m* neighbors for the solution *s*, *m* hyper-rectangles centered on *s* are created, and a point is randomly chosen from each of them. The best of the *m* chosen points then replaces *s*. The search procedure of PSO-TS algorithm will terminate whenever the predetermined maximum number of generations is reached, or whenever the global best solution does not improve over a predetermined number of iterations. The diversification procedure is outlined in the algorithm in Figure 1, while the general flowcharts of the proposed PSO-tabu search are given in Figure 2.

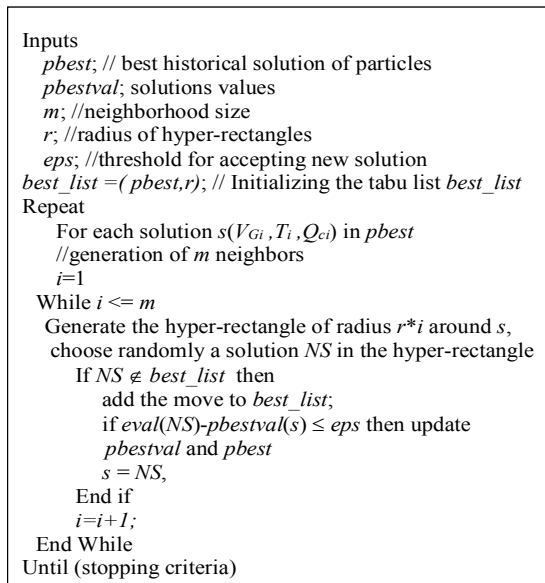

Fig. 1. Tabu search procedure (diversification).

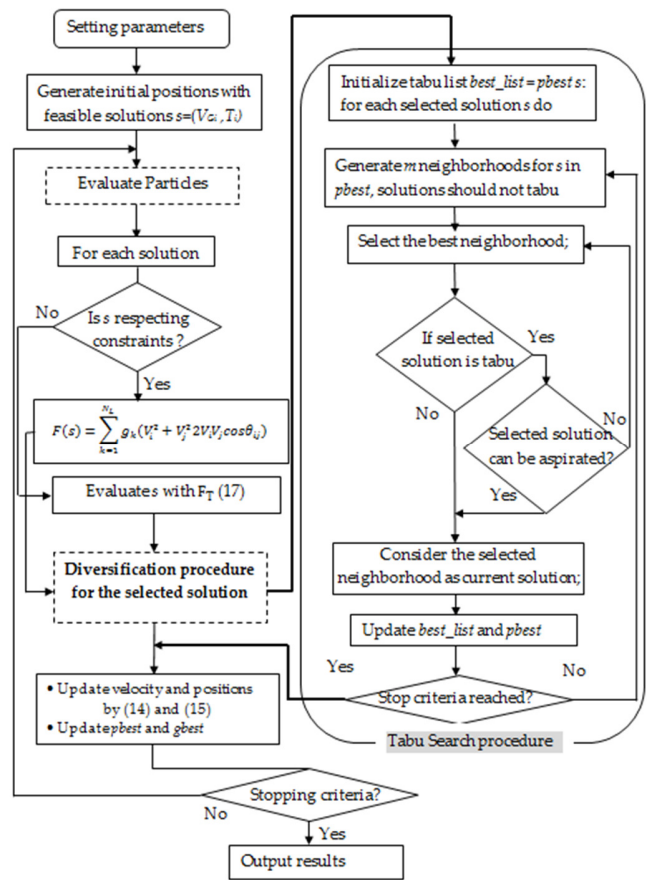

Fig. 2. Flowchart of the proposed PSO-TS algorithm.

IV. SIMULATION RESULTS

In this study, the proposed PSO-TS based reactive power optimization approach was applied to the IEEE 30-bus power system shown in Figure 3 with 12 control variables. Two cases were considered. In the first case, we kept the shunt capacitors on their initial buses [24]. In the second case, the capacitors were installed at the most sensitive buses. A sensitive bus is a load bus which requires the installation of a shunt capacitor. To identify this type of buses and their number, we removed the load from each load bus and calculated the active power losses (P_{Loss}) each time. The bus giving the least active power losses was considered as the most sensitive bus. Table I shows the classification of the sensitive buses according to the new values of the active power losses when the loads of these buses were eliminated. From this Table we can see that the most sensitive buses are: 7, 21, 30, 24, and 19. Therefore, the 2 available shunt capacitors will be installed at buses 7 and 21. All inequality constraints (7)-(13) were taken into consideration. The simulations were carried out in Matlab 7.3 on a Pentium® 3.4GHz computer with 1GB total memory. The PSO-TS parameter selection is a challenging task not only for this algorithm but also for other meta-heuristic algorithms. The parameter settings used in the proposed PSO-TS algorithm, namely initial inertia weight, acceleration factors, number of generations, swarm size, tabu list length, total number of neighborhoods, and neighborhood radius are shown in Table II.

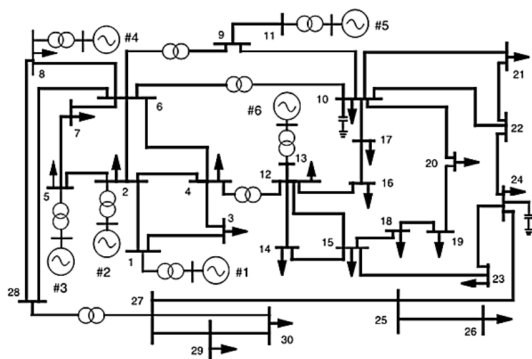

Fig. 3. Single-line diagram of the IEEE 30 bus test system.

TABLE I. CLASSIFICATION OF THE SENSITIVE BUSES

Load bus	New P_{Loss} (MW)	Load bus	New P_{Loss} (MW)
7	4.787	10	5.696
21	4.816	14	5.707
30	5.040	23	5.769
24	5.271	18	5.771
19	5.306	16	5.838
17	5.487	20	5.850
15	5.517	3	5.944
12	5.670	29	5.944
4	5.691		

TABLE II. CONTROL PARAMETER SETTINGS

Parameters	Value
Initial inertia weight w	0.9 and decreased to 0.4
Acceleration factor c_1	2
Acceleration factor c_2	2
Maximum number of generations (PSO)	200
Swarm size	20
Tabu list length	7
Number of neighborhoods	3
Neighborhood radius	0.1
Maximum number of generations (TS)	1000

This system contains 6 generator units connected to buses 1, 2, 5, 8, 11, and 13. Four regulating transformers are connected between the line numbers 6–9, 6–10, 4–12, and 27–28 and two shunt compensators were connected to buses 10 and 24. The transmission feeder number is 41. The generator voltages, transformer tap settings, and VAR injection of the shunt capacitors were considered as control variables. The voltage magnitudes of all the buses were between 0.95 and 1.1pu, transformer tap settings were within the range of 0.9-1.1pu and shunt capacitor sizes were within the interval from 0 to 30MVAR [24]. There are 12 control variables in this case, namely 6 generator voltages, 4 transformer taps and 2 capacitor banks. The initial total P_{Loss} before optimization was 5.2783MW. In the first case study, the shunt capacitors are installed at buses 10 and 24 as in [24]. In the second case study, the shunt capacitors are placed at the most sensitive buses, namely 7 and 21. Table III summarizes the results of the optimal settings and the system power losses obtained by the proposed PSO-TS approach, standalone PSO and TS, and the methods reported in [24, 25], namely CA, IP-OPF, LPAC, GPAC, and BBO. For the case 1, the results show that the dispatch optimal solutions determined by the PSO-TS led to better results. The achieved active power losses are lower than

those found by the other methods. Using the PSO-TS algorithm, power losses decrease from 5.2783MW to 4.6304MW, indicating a reduction of 12.27%, while standalone PSO and standalone TS reduce power losses by only 1.03% and 5.61% respectively. For the other optimization algorithms, the best result is given by the BBO algorithm [25] which reduces losses by 5.93%. The convergence characteristic of power loss objective function for this case is plotted in Figure 4. From Figure 5, it is clear that the results obtained in case 2 are better than those obtained in case 1. This amelioration is due to the installation of shunt capacitors at the most sensitive buses. The active power losses obtained by the PSO-TS method in case 2 decrease from 5.2783MW to 4.6095MW, indicating a reduction of 12.67% which is better than the reduction obtained in case 1. It can be concluded that the proposed PSO-TS method is able to determine a near-global optimal solution. At the same time, the proposed method succeeded in keeping the dependent variables within their limits. The convergence characteristics of power loss objective function for this case is plotted in Figure 6.

As the hardware and the software environment significantly affect the computational time, it is not possible to compare the computational time requirements of the different methods unless all the methods are run on the same hardware and are programmed using the same environment. As a rough guide, however, the average time taken by PSO-TS is 19s.

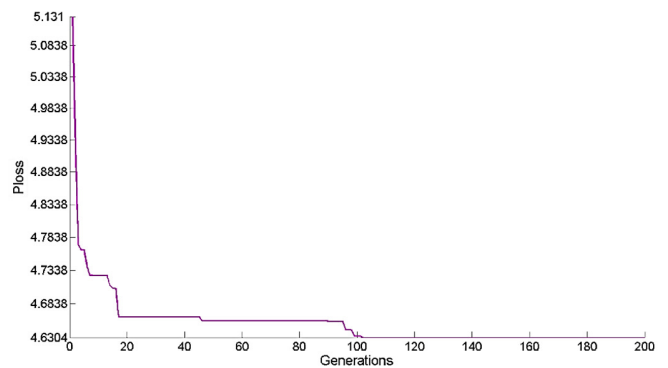

Fig. 4. Convergence characteristic of the power losses (case 1).

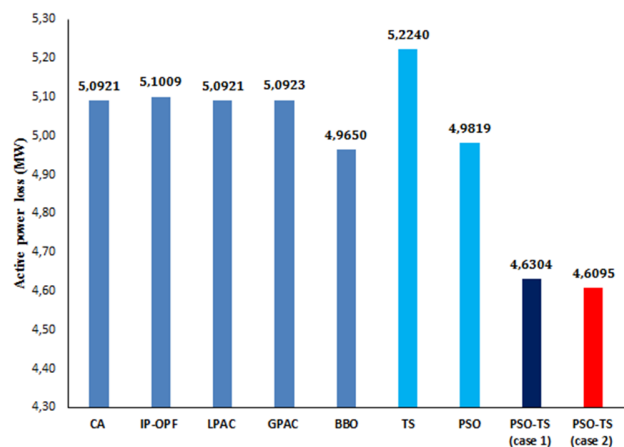

Fig. 5. Comparative graph of the power losses.

TABLE III. EXPERIMENTAL RESULTS OF THE PROPOSED AND OTHER KNOWN ALGORITHMS

Control variables	CA	IP-OPF	LPAC	GPAC	BBO	TS	PSO	PSO-TS (case 1)	PSO-TS (case 2)
V_1	1.02282	1.10000	1.02342	1.02942	1.1000	1.0684	1.1000	1.0992	1.0990
V_2	1.09093	1.05414	0.99893	1.00645	1.0943	1.0933	1.0943	1.0948	1.1000
V_5	1.03008	1.10000	0.99469	1.01692	1.0804	1.0893	1.1000	1.0766	1.0687
V_8	0.95000	1.03348	1.01364	1.03952	1.0939	1.0853	1.1000	1.0977	1.1000
V_{11}	1.04289	1.10000	1.01647	1.03952	1.1000	1.0017	0.9505	1.0837	1.1000
V_{13}	1.03921	1.01497	1.01101	1.04870	1.1000	1.0780	1.1000	1.0754	1.1000
T_{6-9}	1.07894	0.99334	1.04247	1.04225	1.1000	0.9979	1.0547	0.9257	0.9072
T_{6-10}	0.94276	1.05938	0.99432	0.99417	0.9058	0.9008	1.1000	1.0291	0.9399
T_{4-12}	1.00064	1.00879	1.00061	1.00218	0.9521	1.0337	0.9000	0.9265	0.9000
T_{27-28}	1.00693	0.99712	1.00694	1.00751	0.9638	0.9441	0.9468	0.9422	0.9149
Q_{sh10}	0.15232	0.15253	0.17737	0.17267	0.2891	0.1395	0.3000	0.2864	-
Q_{sh24}	0.06249	0.08926	0.06172	0.06539	0.1007	0.1838	0.0000	0.1363	-
Q_{sh07}									0.1285
Q_{sh21}									0.2052
P_{loss} (MW)	5.09209	5.10091	5.09212	5.09226	4.9650	5.2240	4.9819	4.6304	4.6095

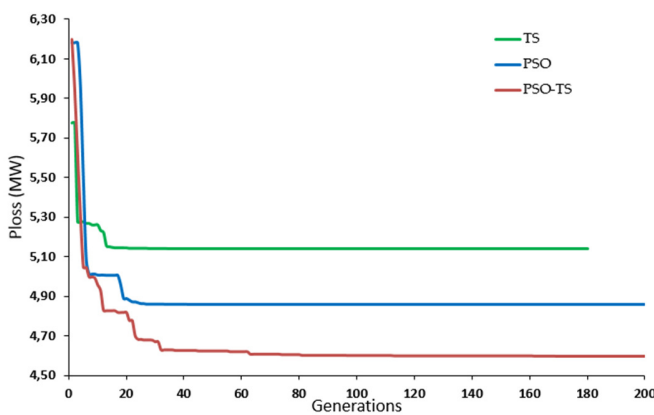

Fig. 6. Convergence characteristic of the power losses (case 2).

V. CONCLUSION

In this paper, a new efficient hybrid PSO-TS strategy was successfully implemented to solve the ORPF problem. This problem was formulated as a highly constrained non-linear optimization problem where all realistic constraints were taken into consideration. The proposed hybrid algorithm combines the exploration ability of the PSO algorithm and the exploitation ability of TS technique. In order to illustrate the application of the proposed method, it has been tested and examined on the standard IEEE 30-bus test system. Two case studies were considered. In the first case, we kept the shunt capacitors on their initial nodes. In the second case, the capacitors were installed at the most sensitive buses. The computational results show that the proposed hybrid approach, with a judicious choice of control parameters, has the ability to converge to high quality solutions with stable convergence characteristic and good computation efficiency. The comparison of the results with TS, PSO, and with various techniques reported in the literature, confirms the superiority of the proposed method and its potential to find accurate and feasible optimal solutions for the ORPF problem.

REFERENCES

[1] B. Zhao, C. X. Guo, and Y. J. Cao, "A multiagent-based particle swarm optimization approach for optimal reactive power dispatch," *IEEE*

Transactions on Power Systems, vol. 20, no. 2, pp. 1070–1078, Feb. 2005, <https://doi.org/10.1109/TPWRS.2005.846064>.

[2] H. Yapici, "Solution of optimal reactive power dispatch problem using pathfinder algorithm," *Engineering Optimization*, vol. 53, no. 11, pp. 1946–1963, Aug. 2021, <https://doi.org/10.1080/0305215X.2020.1839443>.

[3] A. Abbasy and S. H. Hosseini, "Ant Colony Optimization-Based Approach to Optimal Reactive Power Dispatch: A Comparison of Various Ant Systems," in *IEEE Power Engineering Society Conference and Exposition in Africa - PowerAfrica*, Johannesburg, South Africa, Jul. 2007, pp. 1–8, <https://doi.org/10.1109/PESAfr.2007.4498067>.

[4] B. Zhao, C. X. Guo, and Y. J. Cao, "An improved particle swarm optimization algorithm for optimal reactive power dispatch," in *IEEE Power Engineering Society General Meeting*, San Francisco, CA, USA, Jun. 2005, pp. 272-279 Vol. 1, <https://doi.org/10.1109/PES.2005.1489159>.

[5] N. Deeb and S. M. Shahidehpour, "Linear reactive power optimization in a large power network using the decomposition approach," *IEEE Transactions on Power Systems*, vol. 5, no. 2, pp. 428–438, Feb. 1990, <https://doi.org/10.1109/59.54549>.

[6] K. Y. Lee, Y. M. Park, and J. L. Ortiz, "A United Approach to Optimal Real and Reactive Power Dispatch," *IEEE Transactions on Power Apparatus and Systems*, vol. PAS-104, no. 5, pp. 1147–1153, Feb. 1985, <https://doi.org/10.1109/TPAS.1985.323466>.

[7] J. S. Horton and L. L. Grigsby, "Voltage Optimization Using Combined Linear Programming and Gradient Techniques," *IEEE Transactions on Power Apparatus and Systems*, vol. PAS-103, no. 7, pp. 1637–1643, Jul. 1984, <https://doi.org/10.1109/TPAS.1984.318645>.

[8] S. S. Sachdeva and R. Billinton, "Optimum Network Var Planning by Nonlinear Programming," *IEEE Transactions on Power Apparatus and Systems*, vol. PAS-92, no. 4, pp. 1217–1225, Jul. 1973, <https://doi.org/10.1109/TPAS.1973.293803>.

[9] K. Mahadevan and P. S. Kannan, "Comprehensive learning particle swarm optimization for reactive power dispatch," *Applied Soft Computing*, vol. 10, no. 2, pp. 641–652, Nov. 2010, <https://doi.org/10.1016/j.asoc.2009.08.038>.

[10] V. H. Quintana and M. Santos-Nieto, "Reactive-power dispatch by successive quadratic programming," *IEEE Transactions on Energy Conversion*, vol. 4, no. 3, pp. 425–435, Sep. 1989, <https://doi.org/10.1109/60.43245>.

[11] S. Granville, "Optimal reactive dispatch through interior point methods," *IEEE Transactions on Power Systems*, vol. 9, no. 1, pp. 136–146, Oct. 1994, <https://doi.org/10.1109/59.317548>.

[12] M. A. Abido, "Optimal power flow using particle swarm optimization," *International Journal of Electrical Power & Energy Systems*, vol. 24, no. 7, pp. 563–571, Jul. 2002, [https://doi.org/10.1016/S0142-0615\(01\)00067-9](https://doi.org/10.1016/S0142-0615(01)00067-9).

- [13] W. N. W. Abdullah, H. Saibon, A. A. M. Zain, and K. L. Lo, "Genetic algorithm for optimal reactive power dispatch," in *Proceedings of EMPD '98. 1998 International Conference on Energy Management and Power Delivery (Cat. No.98EX137)*, Singapore, Singapore, Mar. 1998, vol. 1, pp. 160–164 vol.1, <https://doi.org/10.1109/EMPD.1998.705494>.
- [14] A. A. A. E. Ela, M. A. Abido, and S. R. Spea, "Differential evolution algorithm for optimal reactive power dispatch," *Electric Power Systems Research*, vol. 81, no. 2, pp. 458–464, Oct. 2011, <https://doi.org/10.1016/j.epsr.2010.10.005>.
- [15] K. Teeparthi and D. M. V. Kumar, "Dynamic Power System Security Analysis Using a Hybrid PSO-APO Algorithm," *Engineering, Technology & Applied Science Research*, vol. 7, no. 6, pp. 2124–2131, Dec. 2017, <https://doi.org/10.48084/etasr.1477>.
- [16] T. L. Duong and T. T. Nguyen, "Application of Sunflower Optimization Algorithm for Solving the Security Constrained Optimal Power Flow Problem," *Engineering, Technology & Applied Science Research*, vol. 10, no. 3, pp. 5700–5705, Jun. 2020, <https://doi.org/10.48084/etasr.3511>.
- [17] Q. H. Wu and J. T. Ma, "Power system optimal reactive power dispatch using evolutionary programming," *IEEE Transactions on Power Systems*, vol. 10, no. 3, pp. 1243–1249, Dec. 1995, <https://doi.org/10.1109/59.466531>.
- [18] H. Pulluri, R. Naresh, and V. Sharma, "Application of stud krill herd algorithm for solution of optimal power flow problems," *International Transactions on Electrical Energy Systems*, vol. 27, no. 6, 2017, Art. no. e2316, <https://doi.org/10.1002/etep.2316>.
- [19] K. ben oualid Medani, S. Sayah, and A. Bekrar, "Whale optimization algorithm based optimal reactive power dispatch: A case study of the Algerian power system," *Electric Power Systems Research*, vol. 163, pp. 696–705, Jul. 2018, <https://doi.org/10.1016/j.epsr.2017.09.001>.
- [20] A. Q. H. Badar, B. S. Umre, and A. S. Junghare, "Reactive power control using dynamic Particle Swarm Optimization for real power loss minimization," *International Journal of Electrical Power & Energy Systems*, vol. 41, no. 1, pp. 133–136, Jul. 2012, <https://doi.org/10.1016/j.ijepes.2012.03.030>.
- [21] U. Khaled, A. M. Eltamaly, and A. Beroual, "Optimal Power Flow Using Particle Swarm Optimization of Renewable Hybrid Distributed Generation," *Energies*, vol. 10, no. 7, Jul. 2017, Art. no. 1013, <https://doi.org/10.3390/en10071013>.
- [22] B. Shaw, V. Mukherjee, and S. P. Ghoshal, "Solution of reactive power dispatch of power systems by an opposition-based gravitational search algorithm," *International Journal of Electrical Power & Energy Systems*, vol. 55, pp. 29–40, Oct. 2014, <https://doi.org/10.1016/j.ijepes.2013.08.010>.
- [23] R. Thangaraj, M. Pant, A. Abraham, and P. Bouvry, "Particle swarm optimization: Hybridization perspectives and experimental illustrations," *Applied Mathematics and Computation*, vol. 217, no. 12, pp. 5208–5226, Oct. 2011, <https://doi.org/10.1016/j.amc.2010.12.053>.
- [24] J. G. Vlachogiannis and K. Y. Lee, "A Comparative Study on Particle Swarm Optimization for Optimal Steady-State Performance of Power Systems," *IEEE Transactions on Power Systems*, vol. 21, no. 4, pp. 1718–1728, Aug. 2006, <https://doi.org/10.1109/TPWRS.2006.883687>.
- [25] P. K. Roy, S. P. Ghoshal, and S. S. Thakur, "Optimal VAR control for improvements in voltage profiles and for real power loss minimization using Biogeography Based Optimization," *International Journal of Electrical Power & Energy Systems*, vol. 43, no. 1, pp. 830–838, Sep. 2012, <https://doi.org/10.1016/j.ijepes.2012.05.032>.
- [26] R. Mallipeddi, S. Jeyadevi, P. N. Suganthan, and S. Baskar, "Efficient constraint handling for optimal reactive power dispatch problems," *Swarm and Evolutionary Computation*, vol. 5, pp. 28–36, May 2012, <https://doi.org/10.1016/j.swevo.2012.03.001>.
- [27] J. Chuanwen and E. Bompard, "A hybrid method of chaotic particle swarm optimization and linear interior for reactive power optimisation," *Mathematics and Computers in Simulation*, vol. 68, no. 1, pp. 57–65, Oct. 2005, <https://doi.org/10.1016/j.matcom.2004.10.003>.
- [28] B. Bhattacharyya, S. K. Goswami, and R. C. Bansal, "Hybrid fuzzy particle swarm optimization approach for reactive power optimization," *Journal of Electrical Systems*, vol. 5, no. 3, pp. 1–15, 2009.
- [29] E. Naderi, H. Narimani, M. Fathi, and M. R. Narimani, "A novel fuzzy adaptive configuration of particle swarm optimization to solve large-scale optimal reactive power dispatch," *Applied Soft Computing*, vol. 53, pp. 441–456, Dec. 2017, <https://doi.org/10.1016/j.asoc.2017.01.012>.
- [30] Y. Li *et al.*, "Optimal Reactive Power Dispatch Using Particle Swarms Optimization Algorithm Based Pareto Optimal Set," in *6th International Symposium on Neural Networks*, Wuhan, China, May 2009, pp. 152–161, https://doi.org/10.1007/978-3-642-01513-7_17.
- [31] M. A. M. Shaheen, H. M. Hasanien, and A. Alkuhayli, "A novel hybrid GWO-PSO optimization technique for optimal reactive power dispatch problem solution," *Ain Shams Engineering Journal*, vol. 12, no. 1, pp. 621–630, Nov. 2021, <https://doi.org/10.1016/j.asej.2020.07.011>.
- [32] S. Sayah and A. Hamouda, "A hybrid differential evolution algorithm based on particle swarm optimization for nonconvex economic dispatch problems," *Applied Soft Computing*, vol. 13, no. 4, pp. 1608–1619, Dec. 2013, <https://doi.org/10.1016/j.asoc.2012.12.014>.
- [33] M. Mehdinejad, B. Mohammadi-Ivatloo, R. Dadashzadeh-Bonab, and K. Zare, "Solution of optimal reactive power dispatch of power systems using hybrid particle swarm optimization and imperialist competitive algorithms," *International Journal of Electrical Power & Energy Systems*, vol. 83, pp. 104–116, Sep. 2016, <https://doi.org/10.1016/j.ijepes.2016.03.039>.
- [34] K. Lenin, B. R. Reddy, and M. S. Kalavathi, "Hybrid Genetic Algorithm and Particle Swarm Optimization (HGAPSO) Algorithm for Solving Optimal Reactive Power Dispatch Problem," *International Journal of Electronics and Electrical Engineering*, vol. 1, no. 4, pp. 262–268, 2013, <https://doi.org/10.12720/ijeee.1.4.262-268>.
- [35] S. Mugemanyi, Z. Qu, F. X. Rugema, Y. Dong, C. Bananeza, and L. Wang, "Optimal Reactive Power Dispatch Using Chaotic Bat Algorithm," *IEEE Access*, vol. 8, pp. 65830–65867, 2020, <https://doi.org/10.1109/ACCESS.2020.2982988>.
- [36] S. Mugemanyi, Z. Qu, F. X. Rugema, Y. Dong, C. Bananeza, and L. Wang, "Optimal Reactive Power Dispatch Using Chaotic Bat Algorithm," *IEEE Access*, vol. 8, pp. 65830–65867, 2020, <https://doi.org/10.1109/ACCESS.2020.2982988>.
- [37] Z. M. Zohrabad, "Application of Hybrid HS and Tabu Search Algorithm for Optimal Location of FACTS Devices to Reduce Power Losses in Power Systems," *Engineering, Technology & Applied Science Research*, vol. 6, no. 6, pp. 1217–1220, Dec. 2016, <https://doi.org/10.48084/etasr.725>.
- [38] R. Eberhart and J. Kennedy, "A new optimizer using particle swarm theory," in *Sixth International Symposium on Micro Machine and Human Science*, Nagoya, Japan, Oct. 1995, pp. 39–43, <https://doi.org/10.1109/MHS.1995.494215>.
- [39] X. Hu and R. Eberhart, "Solving Constrained Nonlinear Optimization Problems with Particle Swarm Optimization," in *6th World Multiconference on Systemics, Cybernetics and Informatics*, Orlando, FL, USA, Jul. 2002, pp. 203–206.
- [40] F. Glover and M. Laguna, "Tabu Search," in *Handbook of Combinatorial Optimization*, D.-Z. Du and P. M. Pardalos, Eds. Boston, MA, USA: Springer, 1998, pp. 2093–2229.
- [41] R. Chelouah and P. Siarry, "Enhanced Continuous Tabu Search: An Algorithm for Optimizing Multimimima Functions," in *Meta-Heuristics: Advances and Trends in Local Search Paradigms for Optimization*, Boston, MA, USA: Springer, 1999, pp. 49–61.