



HAL
open science

A State of the Art in Feedforward-Feedback Learning Control Systems for Human Errors Prediction

Kiswendsida Abel Ouedraogo, Simon Enjalbert, Frédéric Vanderhaegen

► **To cite this version:**

Kiswendsida Abel Ouedraogo, Simon Enjalbert, Frédéric Vanderhaegen. A State of the Art in Feedforward-Feedback Learning Control Systems for Human Errors Prediction. 18th World Congress of the International Federation of Automatic Control (IFAC), Aug 2011, Milano, Italy. pp.7390-7395, 10.3182/20110828-6-IT-1002.03483 . hal-03644268

HAL Id: hal-03644268

<https://uphf.hal.science/hal-03644268>

Submitted on 25 Apr 2022

HAL is a multi-disciplinary open access archive for the deposit and dissemination of scientific research documents, whether they are published or not. The documents may come from teaching and research institutions in France or abroad, or from public or private research centers.

L'archive ouverte pluridisciplinaire **HAL**, est destinée au dépôt et à la diffusion de documents scientifiques de niveau recherche, publiés ou non, émanant des établissements d'enseignement et de recherche français ou étrangers, des laboratoires publics ou privés.

A State of the Art in Feedforward-Feedback Learning Control Systems for Human Errors Prediction

Kiswendsida Abel Ouedraogo^{1,2,3}, Simon Enjalbert^{1,2,3}, Frédéric Vanderhaegen^{1,2,3}

¹Univ Lille Nord de France, F-59000 Lille, France

²UVHC, LAMIH, F-59313 Valenciennes, France

³CNRS, FRE 3304, F-59313 Valenciennes, France

{kiswendsidaabel.ouedraogo, simon.enjalbert, frederic.vanderhaegen}@univ-valenciennes.fr

Abstract: In this paper, authors propose an overview of feedforward-feedback learning control systems that can be adapted for human errors prediction. A State of the Art in existing approaches for machines of feedback and/or feedforward learning control systems is presented and a synthesis relevant for prediction purposes is detailed. The possible application for learning systems based on human errors applied to Human Machine System (HMS) is then identified. A feedforward-feedback learning system applied to car driving simulation in order to predict intentional human errors is proposed. The paper concludes on relevant perspectives for feedforward-feedback learning systems to predict human errors and to increase HMS resilience facing unplanned disruptions in transportation.

Keywords: Human Machine Systems, human error prediction, learning systems.

1. INTRODUCTION

A Human Machine System (HMS) is a system where the human operators and machines cooperate to ensure an optimal operation. Cooperation between human and machine involves usually static knowledge and is also a way for a decision maker to learn from the behaviours of the others (Vanderhaegen, 2010). In transport systems, the risks of accidents are mostly due to human errors; technical factors are relatively well controlled. Human error concept is the capacity of human operators to not achieve their required tasks in predefined conditions or to achieve additional tasks that may damage the system safety.

Several human error analysis methods exist (Vanderhaegen et al., 2011) but they are sometimes inefficient (assessment of human error occurrence probability) and have shown their limits (results not homogeneous). This paper proposed a feedforward-feedback learning approach to predict human error by analysing human behaviour through prognosis and diagnosis function. The prognosis function leads to the identification of the possible evolutions of the system state with or without actions. The diagnosis function relates to the explanation of the current system state regarding the previous ones.

HMS is regularly subject to external and/or internal disturbances. Systems engineering design try to anticipate and resist to these disruptions but may be vulnerable to critical or unexpected factors. Facing unexpected events, HMS have to manage its knowledge dynamically in order to overcome an issue. The system has to apply some behaviour from a model which involves the capacities to identify the state of a given process in order to produce

hypotheses on its evolution. Figure 1 details two human behaviours approaches based on the diagnosis, the prognosis and/or the trial-and-error functions.

In the first approach, the current state can be identified by experience when system faces a known situation. Thus, a prognosis on the future states of the system can be determined *e.g.* by feedforward control, which is to assess or predict the future states based on the current state and various parameters of HMS. If the current state cannot be identified, in case of an unplanned event occurrence or of a prognosis not possible, a diagnosis will be performed *e.g.* by feedback control related to the previous states of the system in order to assess current one.

To sum up, if the current state of HMS can be identified or assessed by diagnosis, then a prognosis related to the reachable future states is done in order to select appropriate alternatives or reactions to recover from disruption.

The second approach focuses on the occurrence of a new unforeseen or unprecedented situation. In this case, identification, prognosis and diagnosis are not possible. Several behaviours can then be applied:

- The “trial-and-error” process, *i.e.*, performing actions without knowing consequences on the HMS and recovering erroneous ways. Actions can be performed iteratively for repetitive systems tasks, by experience or through a feedback-feedforward control model.
- The “Wait and see” process, *i.e.*, waiting for the consequences of a given action in order to identify the current state of the controlled system.

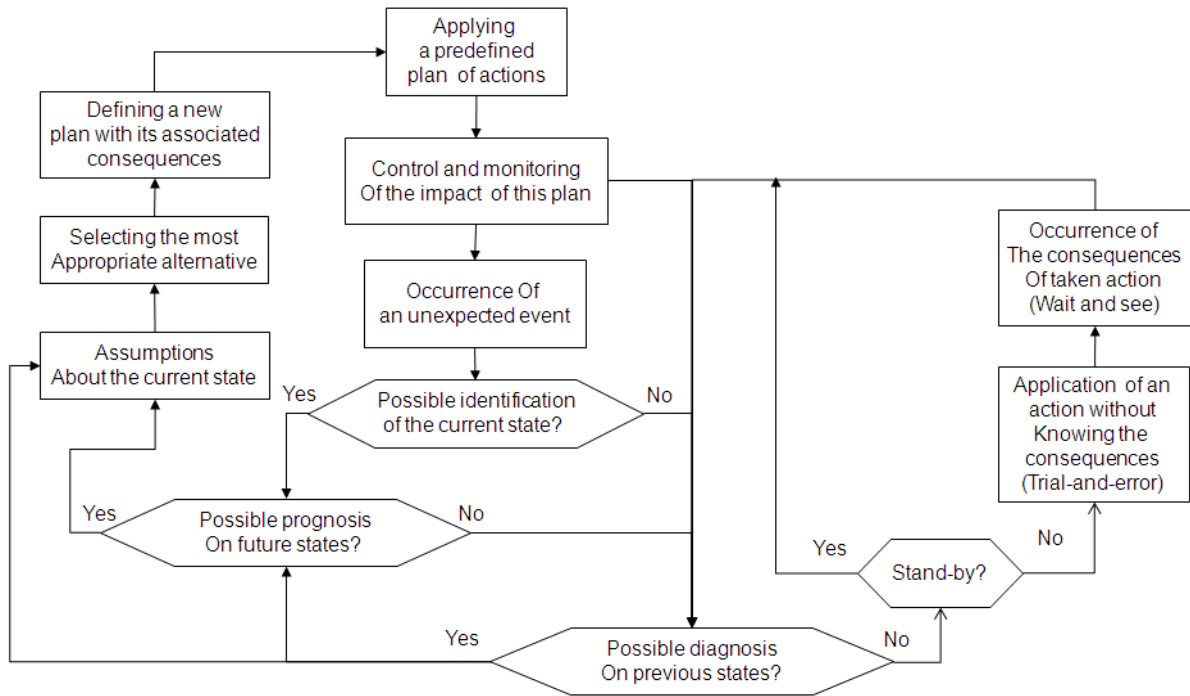

Figure 1. Human behaviour in response to unexpected events (adapted from Ouedraogo et al., 2010a).

The purpose of the algorithm illustrated in Figure 1 is to achieve the selection of the most appropriate alternative and to define a new action plan with its associated consequences that will be applied to HMS (Ouedraogo et al., 2010a & 2010b). This paper focuses on the feedforward-feedback learning control systems in order to predict human errors. Thus the second section of this paper details, through a State of the Art, the existing approaches of feedback and/or feedforward learning control processes for machines by focusing on relevant ones for this study. The final section presents the proposal made in terms of feedforward-feedback approach in order to apply it on HMS during car driving simulation.

2. A STATE OF THE ART IN FEEDFORWARD-FEEDBACK LEARNING CONTROL SYSTEMS

The feedforward process aims at assessing the future possible decisions regarding the current system states and the management of the previous ones. The feedback aims at recovering possible erroneous knowledge, at refining knowledge or at creating new knowledge (Vanderhaegen, 2010). So the feedforward-feedback mechanism that consists in using the current knowledge related to previous activities in order to calculate the future ones. A great number of research works have proposed feedback and/or feedforward controllers using different methods in order to reach the mentioned objectives. There are frequency based approach (related to iteration frequency) or temporal based approach (related to timing process).

In Figures 2 & 3, the idea developed is to use iterative learning control (ILC) to benefit from the repetitive nature of the tasks as experience gained to compensate for the poor or incomplete knowledge of the plant model and disturbance. The repeatability of the task determines the learning ability of the ILC. Essentially, the proposed

control structures also use a feedforward-feedback configuration.

Xu et al. defined a formalism, given in equation (1), of a global ILC based system in (Xu et al., 2004b).

$$u_i = u_{i-1} + G(e_i, e_{i-1}) \quad (1)$$

The previous and current cycle learning (PCCL) structure – the previous and the current tracking errors are involved into learning – was proposed with application to a ball-and-beam system (Xu et al., 2004a).

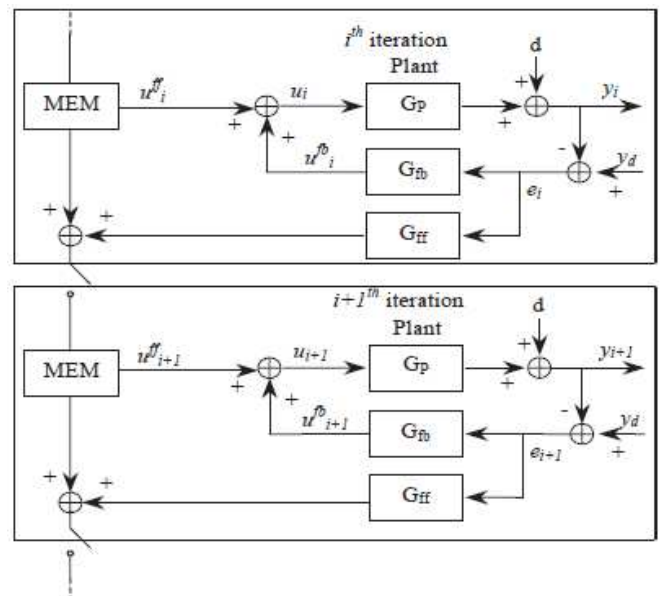

Figure 2. Block diagram of PCCL structure I (from Xu et al., 2004a).

The subscript i denotes the i th iteration. Hence, the reference signal, the output signal, the control signal and the error signal, denoted respectively $y_{d,i}$, y_i , u_i , e_i , at the i th iteration. G_p , G_{fb} and G_{ff} are respectively the transfer functions of the plant, the feedback and the feedforward control compensators. The feedforward portion can be designed in different ways and two configurations of PCCL have been developed: structures I and II.

The first one, PCCL structure I, is shown in Figure 2 and the corresponding learning control updating law is given in equation (2) in Table 1. The convergence condition for the PCCL structure I is:

$$\left\| \frac{e_{i+1}}{e_i} \right\| = \left\| \frac{1 + G_p G_{fb} - G_p G_{ff}}{1 + G_p G_{fb}} \right\| \leq \rho < 1. \quad (8)$$

With ρ : a minimum threshold of the tracking error.

The second one, PCCL structure II, the feedforward portion is different. Lee et al. proposed a same structure for the trajectory tracking of a linear Direct Current motor with updating law given in equation (3) in Table 1 (Lee et al., 2000). The convergence condition for the PCCL structure II is:

$$\left\| \frac{e_{i+1}}{e_i} \right\| = \left\| \frac{1 - G_p G_{ff}}{1 + G_p G_{fb}} \right\| \leq \rho < 1. \quad (9)$$

The essential difference between the two PCCL structures, which can be exploit in learning performance, is the error through G_{fb} incorporated into the next updating in PCCL structure I. PCCL structure I will be better than structure II if and only if:

$$\left\| 1 + G_p G_{fb} - G_p G_{ff} \right\| < \left\| 1 - G_p G_{ff} \right\| \quad (10)$$

For practical applications, PCCL structure II is recommended for it better performances; it manage just feedforward controller (G_{ff}) while structure I manage both ($G_{ff} G_{fb}$).

Jang et al. have proposed a feedback-feedforward structure similar to PCCL structure II, for sharp tracking control of a manipulator robot, by employing an input saturator $\gamma(\cdot)$ which limits the control input within a reasonable bound (Jang et al., 1995). The corresponding learning control updating law is equation (4) in Table 1. The class of nonlinear systems to which the proposed learning scheme can be applied is extended.

Lee and Lee used the recursive process of iterative learning control technique to assess the current characteristics and to improve tracking control performance in batch processes (Lee and Lee, 2007). The corresponding learning control updating law is equation (5) in Table 1. The formalism can be seen as a generalization of the previous ones: the control is done regarding the previous errors at certain level because of limited memory capacity.

Yan and Shiu proposed a combined feedback-feedforward controller and disturbance observer, depicted in Figure 3,

designed for a direct drive motion control (Yan and Shiu, 2008). The digital disturbance observer is included in the proposed feedback–feedforward control structure to compensate for disturbance (friction, cogging effects). The corresponding learning control updating law is equation (6) in Table 1.

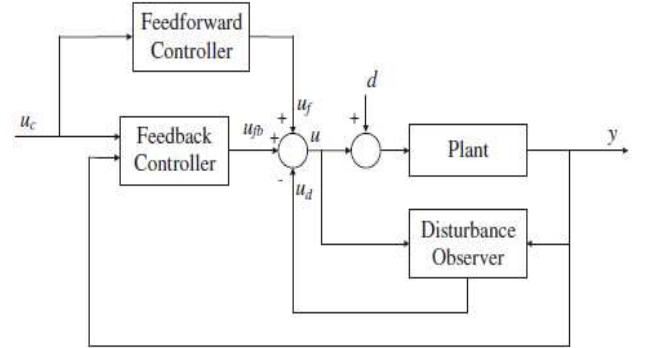

Figure 3. Diagram of a combined feedback-feedforward controller structure and a disturbance observer (from Yan and Shiu, 2008).

Vanderhaegen et al. have proposed a framework for the assessment of the consequences of human errors based on learning and prediction of the actions of a human operator (Vanderhaegen et al., 2009). The corresponding learning control updating law is given in equation (7) in Table 1. These processes are modelled by using the iterative learning control concept and by integrating it in a feedforward-feedback approach.

ILC has become a competitive control method through the development of different learning controllers for many applications, essentially in robotic operations, chemical processes and motor drive machines. Initially the ILC input signal is formed using the error from previous iterations, i.e., the input u_i is computed using of cause the previous input u_{i-1} :

- And e_{i-1} (Xu et al., 2004a)'s so-called previous cycle learning (PCL).
- Or recursively $e_{i-1}, e_{i-2}, \dots, e_{i-p}$ (Lee and Lee, 2007).

Several authors have computed the input u_i using the current tracking error e_i (Xu et al., 2004a)'s so-called current cycle learning (CCL). Recently it has been proposed to combine the current error, e_i with the previous one e_{i-1} , when forming u_i (Xu et al., 2004a; Lee et al., 2000; Jang et al., 1995; Xu et al., 2004b). This approach leads to a causal relationship between the current error and the input signal. It can be seen that PCL and CCL are functioning a complementary manner (Xu et al., 2004a) with the aim to improve the control performance through PCCL structure – complementary role of feedback and feedforward structures.

Table 1. Feedforward and/or feedback learning control formalisms.

References	Formula	Principle
Xu et al., 2004a	$u_i = u_{i-1} + (G_{ff} - G_{fb})e_{i-1} + G_{fb}e_i \quad (2)$	The use of current and previous tracking errors (e_i, e_{i-1}) and the previous input u_{i-1} to assess the current input u_i . The previous error through G_{fb} is also use.
Xu et al., 2004a Lee et al., 2000;	$u_i = u_{i-1} + G_{ff}e_{i-1} + G_{fb}e_i \quad (3)$	The use of current and previous tracking errors (e_i, e_{i-1}) and the previous input u_{i-1} to assess the current input u_i .
Jang et al., 1995 with an input saturator $\gamma(\cdot)$	$u_i = \gamma(v_i = u_{i-1} + G_{ff}e_{i-1} + G_{fb}e_i) \quad (4)$	
Lee and Lee, 2007	$u_i = u_{i-1} + G_1(e_{i-1}) + G_2(e_{i-2}) + \dots + G_p(e_{i-p}) \quad (5)$	The use of a recursive process to assess the current characteristics.
Yan and Shiu, 2008	$\begin{aligned} u_i &= u_i^{ff} + u_i^{fb} - u_i^d \\ &= G_{ff}(e_{i-1}, u_{i-1}) + G_{fb}e_i - G_d(e_{i-1}, u_{i-1}) \end{aligned} \quad (6)$	The assessment of the current input u_i regarding the current tracking error and the previous couples (e_{i-1}, u_{i-1}) through a feedforward system and a digital disturbance observer.
Vanderhaegen et al., 2009	$u_i = e_i + G((e_{i-1}, u_{i-1}), (e_{i-2}, u_{i-2}), \dots, (e_0, u_0)) \quad (7)$	The assessment of the current input u_i regarding the current tracking error and the previous couples (e_{i-1}, u_{i-1}).

Vanderhaegen et al. have extended this approach by using the previous couples ($(e_{i-1}, u_{i-1}), \dots, (e_0, u_0)$). The proposed feedforward-feedback learning control systems have their updating laws mostly depend on current and/or previous errors. According to equations (8) and (9), the more the systems errors are predicted and minimized to become within ρ (a minimum error threshold), the more these systems learning capacity can be improved. In the same way, the prediction of human errors leads to the HMS learning capacity and performance improvement.

Through the formalisms, the process output errors are determined:

For PCCL structure I, equation (8) leads to:

$$e_i = \left(\frac{1 + G_p G_{fb} - G_p G_{ff}}{1 + G_p G_{fb}} \right) e_{i-1} \quad (11)$$

For PCCL structure II, equation (9) leads to:

$$e_i = \left(\frac{1 - G_p G_{ff}}{1 + G_p G_{fb}} \right) e_{i-1} \quad (12)$$

We have observed from equation (11) and (12) that the output errors prediction depends on both feedforward (G_{ff}) and feedback (G_{fb}) processes. By managing the feedforward and/or feedback systems, the error ratio through the

iterations is reduced. These principles can be applied for human errors prediction (Vanderhaegen et al., 2009).

The formalisms, summarised in Table 1, are used to deal with machines processes control (optimize robot or motor motion) during repetitive tasks – mostly tracking errors performance control – by managing a static knowledge. These control processes are not applied to problems involving humans and do not managed knowledge in unexpected or unprecedented situations.

The originality of (Vanderhaegen et al., 2009)'s model is that it is applied to HMS with the aim to predict human errors and to manage human behaviours even if human errors in the protocol presented in next section are intentional violations. It combines feedforward-feedback processes and use predefined knowledge that is reinforced or corrected regarding the observed previous couples.

A State of the Art has been realized to compare different structures of the feedforward and/or feedback learning control systems in order to select the more appropriate one or to build an efficient one, for improving knowledge on known situations and for creating knowledge related to new situations. In next section, a proposal to apply feedforward-feedback learning system in human machine transportation system is presented.

3. TOWARDS AN APPLICATION OF FEEDFORWARD-FEEDBACK LEARNING SYSTEM TO PREDICT HUMAN ERRORS

All the described feedback-feedforward learning control systems are applied to technical system, *i.e.* machine or process, whereas around 70% of the accidents in transport are due to human errors. Thus, complex systems cannot avoid risks of disaster without the assistance of human operators due to his sense of adaptation. So we aim to apply the feedback-feedforward learning approach to Human-Machine System (HMS).

The general idea of the proposed model is to use past experience of the system, both in success and failure cases, in order to predict actions of the human operator (\hat{u}_i) to manage the occurrence of a perturbation. This requires both a Feedforward System (FFS) and a Feedback System (FBS) based systems in Figure 4.

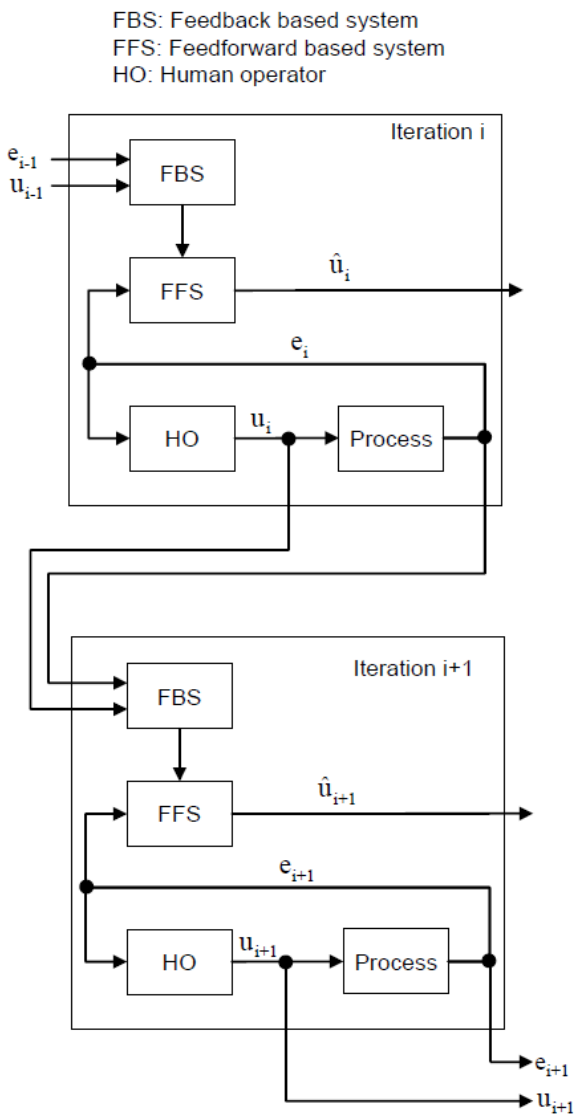

Figure 4. The feedforward-feedback learning system statement (Vanderhaegen, 2010).

The transfer function of this feedforward-feedback learning system is given by equation (7) (Vanderhaegen et al., 2009) in Table 1.

At a given iteration i , the prediction of u_i noted \hat{u}_i requires the activation of the FFS system regarding the process state represented by its outputs noted e_i . These outputs relate to the consequences of the human operators' action on the process. They are anticipated or observed. The comparison between the real human decisions (noted u) and the predicted decisions (noted \hat{u}) allows the dynamic management and reinforcement of the knowledge implemented into the FBS that integrates the data and the decisions of the previous iterations.

The FBS is an iterative process that manages the system knowledge regarding the human actions and their consequences on the process during the previous iterations. For each iteration, a new couple (e_{i-1}, u_{i-1}) has to be included into the system knowledge. A vector e_i contains the same m number of parameters: $(a_1, a_2, a_3, a_4, \dots, a_m)$. Each parameter is supposed to be defined into an interval of values noted $\Omega = [X_{min}, X_{max}]$ and the action u is supposed to be represented into an interval of values noted $\Psi = [0, 1]$.

Then, this feedforward-feedback learning system will be applied to an experimental protocol on a car driving simulation and compared to results obtained in (Vanderhaegen et al., 2011). This experiment consists in predicting barrier removal when controlling the road traffic flow. A barrier removal is an intentional violation related to a non-respect of a rule or a deactivation of a technical system whereas this rule and this technical system were designed to protect the controlled system from the occurrence or the consequences of an undesirable event such as an accident. 44 subjects have participated to this experimental protocol: the priority-to-the-right barrier removal situation. In this specific study, barrier removal means that the drivers did not give way to the vehicle coming from their right. The prediction concerns 61 iterations. 4 iterations are used to initialize the iterative learning system (ILC). The correct prediction rates are up to 90% with the two ILC implementations proposed, the case base reasoning system and the neural network system.

The proposed model intends to combine predictive and learning capacities to increase the relevance of the management of situations such as barrier removals performed by the human operators. The formalism for the ILC process is based on the prediction of the input of a current iteration by taking into account a dynamic knowledge that contains a limited number of past scenarios. Performance of proposed feedback-feedforward learning system will be evaluated across comparison with results obtained in previous experiments.

Several prospective studies are planned. Firstly, application of the proposed model to assess resilience of human machine systems based on Enjalbert et al. proposal for evaluation of resilience by the use of safety indicators for transportation (Enjalbert et al., 2010).

This may lead to answer two issues that will be developed during further works:

- How to manage HMS facing critical situations by using predictions and reinforcing the most successful alternatives present in the knowledge base of the system.
- How to allow the transfer the human operator's knowledge into the machine's one or vice-versa.

Secondly, in unforeseen situation, human operator, due to his adaptation skills, is the most reliable barrier for safety. We may implement on HMS an adaptation part related to human operator dynamics and evolutionary knowledge instead of a static one. Future works aim to propose several extensions of this approach for improving the quality of the human error prediction process in unexpected situation, *e.g.* by adding disturbance observer to take into account HMS internal errors or using diagnosis tree (Chen and Yea, 2007) to controlled output variance of feedforward-feedback control systems or by using previous errors (e_{i-1} , ..., e_0) instead of couples ((e_{i-1}, u_{i-1}) , ..., (e_0, u_0)).

4. CONCLUSION

This study presents the use of the concepts of the feedforward-feedback learning control systems for human errors prediction. A State of the Art in the existing approaches of feedback and/or feedforward learning control processes is proposed by focusing on relevant ones for this study. The synthesis of this overview is discussed based on the application of such learning approaches to human error prediction. Finally, the original approach developed at the LAMIH laboratory is presented and will be extended in further works. Improvements will focus on the quality of the human error prediction process and will be tested through two projects:

- The Information Technology for Error Remediation And Trapping Emergencies (ITERATE) European project from the seventh Framework Program, for the analysis of car and train drivers behaviours.
- The REACT project financed by DGA (French army) to help heterogeneous military units to learn and to react face to unexpected events.

5. ACKNOWLEDGMENTS

The present research work has been supported:
By International Campus on Safety and Intermodality in Transportation,
The Nord-Pas-de-Calais Region,
The European Community,
The Regional Delegation for Research and Technology,
The Ministry of Higher Education and Research,
And the National Center for Scientific Research.
The authors gratefully acknowledge the support of these institutions.

REFERENCES

- Chen, J., Yea, Y. (2007). Controlled output variance based diagnosis tree for feedforward/feedback control systems. *Chemical Engineering Science* 62. 943-956.
- Enjalbert, S., Vanderhaegen, F., Pichon, M., Ouedraogo, K.A., Millot, P. (2010). Assessment of transportation system resilience. *HMAT Workshop, Human Modelling in Assisted Transportation*, Belgirate, Italy, Springer.
- Jang, T.J., Choi, C.H. and Ahn, H.S.. (1995). Iterative Learning Control in Feedback Systems. *Automatica* Vol. 31, No.2, 243-248.
- Lee J.H., Lee K.S. (2007). Iterative learning control applied to batch processes: An overview. *Control Engineering Practice* 15. 1306-1318.
- Lee T.H., Tan K.K., Lim S.Y., Dou H.F. (2000). Iterative learning control of permanent magnet linear motor with relay automatic tuning. *Mechatronics* 10. 169-190.
- Ouedraogo, K.A., Enjalbert, S., Vanderhaegen, F. (2010a). How to learn from the resilience of Human-Machine Systems? *The 11th IFAC/IFIP/IFORS/IEA Symposium on Analysis, Design, and Evaluation of Human-Machine Systems*. August 31 - September 3. Valenciennes, France.
- Ouedraogo, K.A., Enjalbert, S., Vanderhaegen, F. (2010b). Principes de résilience et processus d'apprentissage face à l'imprévu. *6ème Conférence Internationale Francophone d'Automatique*. 2-4 Juin., Nancy, France.
- Vanderhaegen, F. (2010). Autonomy control of Human-Machine Systems. *The 11th IFAC/IFIP/IFORS/IEA Symposium on Analysis, Design, and Evaluation of Human-Machine Systems*. Valenciennes, France.
- Vanderhaegen, F., Polet, P., Zieba, S. (2009). A reinforced iterative formalism to learn from human errors and uncertainty. *Engineering Applications of Artificial Intelligence*, 22 (4-5), 654-659.
- Vanderhaegen F, Zieba S., Enjalbert S., Polet P., (2011). A benefit/cost/deficit (BCD) model for learning from human errors. *Reliability Engineering and System Safety*, doi:10.1016/j.ress.2011.02.002.
- Xu, J.-X., Lee, T.H., Zhang, H.-W. (2004a). Analysis and comparison of iterative learning control schemes. *Engineering Applications of Artificial Intelligence* 17, 675-686.
- Xu, J.-X., Tan Y., Lee, T.H. (2004b). Iterative learning control design based on composite energy function with input saturation. *Automatica* 40, 1371-1377.
- Yan M.-T., Shiu Y.-J. (2008). Theory and application of a combined feedback-feedforward control and disturbance observer in linear motor drive wire-EDM machines. *International Journal of Machine Tools & Manufacture* 48. 388-401.