



**HAL**  
open science

# How to Learn from the Resilience of Human-Machine Systems?

Kiswendsida Abel Ouedraogo, Simon Enjalbert, Frédéric Vanderhaegen

► **To cite this version:**

Kiswendsida Abel Ouedraogo, Simon Enjalbert, Frédéric Vanderhaegen. How to Learn from the Resilience of Human-Machine Systems?. 11th IFAC/IFIP/IFORS/IEA Symposium on Analysis, Design, and Evaluation of Human-Machine Systems, Aug 2010, Valenciennes, France. pp.374-379, 10.3182/20100831-4-FR-2021.00066 . hal-03644372

**HAL Id: hal-03644372**

**<https://uphf.hal.science/hal-03644372v1>**

Submitted on 25 Apr 2022

**HAL** is a multi-disciplinary open access archive for the deposit and dissemination of scientific research documents, whether they are published or not. The documents may come from teaching and research institutions in France or abroad, or from public or private research centers.

L'archive ouverte pluridisciplinaire **HAL**, est destinée au dépôt et à la diffusion de documents scientifiques de niveau recherche, publiés ou non, émanant des établissements d'enseignement et de recherche français ou étrangers, des laboratoires publics ou privés.

# How to Learn from the Resilience of Human-Machine Systems?

Kiswendsida Abel Ouedraogo<sup>1,2,3</sup>, Simon Enjalbert<sup>1,2,3</sup>, Frédéric Vanderhaegen<sup>1,2,3</sup>

<sup>1</sup>Univ Lille Nord de France, F-59000 Lille, France

<sup>2</sup>UVHC, LAMIH, F-59313 Valenciennes, France

<sup>3</sup>CNRS, FRE 3304, F-59313 Valenciennes, France

{kiswendsidaabel.ouedraogo, simon.enjalbert, frederic.vanderhaegen}@univ-valenciennes.fr

---

**Abstract:** In this paper, we aim to analyse the resilience of Human-Machine Systems (HMS) in order to improve it from learning process. A State of Art is achieved and resilience engineering of HMS is defined. Then, human-machines' learning processes supposed to improve systems' resilience and indicators proposed in the literature to assess it are analysed. A perspective can be to propose an efficient indicator, for instance based on Benefit-Cost-Deficit (BCD) model, which can lead to the system resilience characterisation.

**Keywords:** Human-Machine Systems, Resilience, BCD model, Learning process, Feedback/Feedforward control.

---

## 1. INTRODUCTION

A Human-Machine System (HMS) is a system where the human operators and machines cooperate to ensure an optimal operation. In the literature, many studies have focused on the machine system only, not on the response capacity of the whole HMS which is regularly subject to external and/or internal disturbances. In this paper, we analyse resilient systems, *i.e.* HMS able to cope with a disruption in its response capabilities, and how to learn from them.

The article is organized as follows. In the second section, a State of the Art on the concept of resilience is given. Some descriptions of resilient HMS are presented. A few existing formulations to assess the potential resilience of systems are given in the third section; we also introduce a BCD model applied to analyse human activities on a rail simulation. The fourth section describes some structures in order to characterise and enhance HMS resilience. Finally, we give the conclusion and perspectives.

## 2. STATE OF THE ART ON RESILIENCE

Resilience is a relatively new field of research although the concept has been first used in physics for Charpy impact test in 1905 (Jacobs and Kilduff, 2005; Charpy, 1901). Resilience was related to the ability of a material to recover from a shock or disturbance.

The concept of resilience was next developed in the field of ecology and characterises natural systems that tend to maintain their integrity when subject to disturbances (Ludwig et al., 1997). It has generated much interest in different communities and has been applied to: psychology, psychiatry (Goussé, 2005), sociology, economy, biology (Orwin and Wardle, 2004; Pérez-España and Sánchez, 2001), informatics (Chen et al., 2007; Nakayama et al., 2007; Luo and Yang, 2007), automatic (Numanoglu et al., 2006).

In psychology, the concept is linked to the invulnerability theory *i.e.* the positive capacity of people to cope with trauma and to bounce back.

In biology, resilience is developed in the theory of viability *i.e.* ability for an organism to survive after disruption.

In industrial systems, resilience is related to the concept of robustness (Amalberti, 2006) which is related to error-resistant and error-tolerant systems.

In organisational and safety management, resilience is the capacity of a system to survive, adapt and grow face to unforeseen changes, even catastrophic incidents (Zieba et al., 2007).

In HMS, the definition from (Wreathall, 2006) can be adopted: "Resilience is the ability of an organization (system) to maintain, or recover quickly to, a stable state allowing it to continue operations during and after a major mishap or in presence of a continuous stress". That approach incorporated all components of the system (machines, human, and organisation) and their interactions.

The Fig. 1 illustrates some issues: when can we say that HMS is resilient and why? If not, what to do to make it happen? What can we learn from this HMS resilience? In this paper, we focus on defining the HMS resilience and so, how to learn from it.

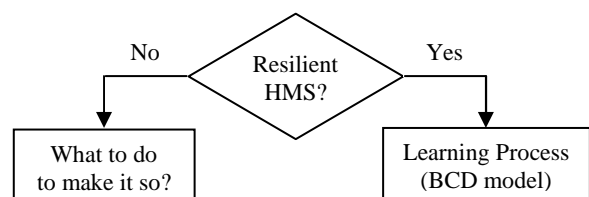

Fig. 1. Pending issues about resilient HMS.

Resilient systems are supposed to adapt to unplanned events by its capacities to anticipate failures, to control disturbances, to react and to recover from unexpected events. These systems organisation is illustrated in Fig. 2. The system has also the possibility to learn from its reactions to unplanned events.

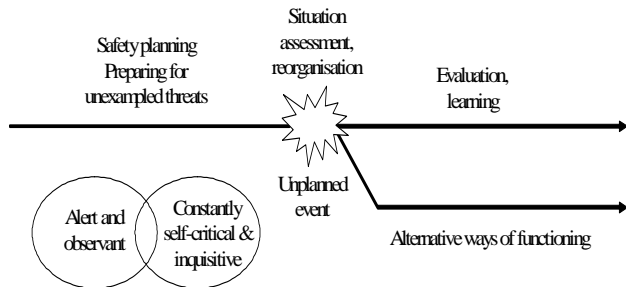

Fig. 2. Resilient organisation (from Hollnagel, 2006).

(Hollnagel and Woods, 2006) have described resilience as a form of control. So, in order to be “in control” it is necessary to know what has happened (the past), what happens (the present) and what may happen (the future), as well as knowing what to do and having the required resources to do it. The resilient HMS must have some characteristics that authors described as resilience’s components. Fig. 3 illustrates three qualities or resilience components (knowledge, competence and resources) that a system must have to be able to remain in control, and therefore to be resilient.

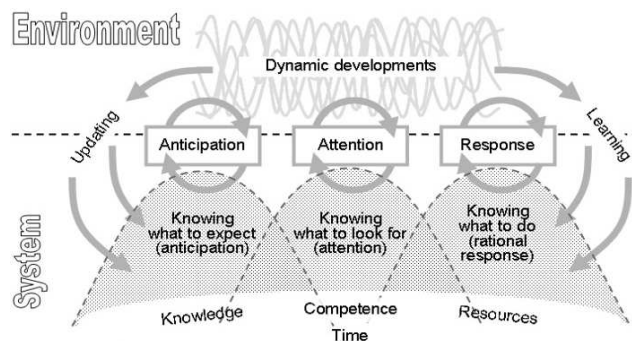

Fig. 3. Required qualities of a resilient system (from Hollnagel and Woods, 2006).

These qualities must be exercised continuously. Knowledge is needed in order to recognise what to expect or where to focus next (anticipation). The competence refers to know what to look for or where to pay attention. The resources refer to the ability to know what to do and how to do it (Hollnagel and Woods, 2006). The system must constantly update its knowledge, competence and resources by learning from successes and failures.

A non resilient system cannot continue to operate after a major mishap or in presence of continuous stress. Then how can it be done? Several mechanisms can be established for instance:

- Using non-affected elements to compensate and achieve the functions of parts affected (Chen et al., 2007; Nakayama et al., 2007; Numanoglu et

al., 2006). What works compensates what does not;

- Maintaining the system between minimum and maximum thresholds (acceptability domain) rather than a stability value (Martin, 2005);
- Putting critical elements in redundancy (Luo and Yang, 2007). The affected elements are no longer solicited and are replaced by redundant components;
- Learning or re-learning the affected elements to work correctly or to work better (Cheveau and Wybo, 2007). What does not work is reset and prepared for a future operation;
- Learning initial functions for Human *i.e.* the ability to develop attitudes or behaviours ensuring the survival of the organism (Marcantoni, 2009).

### 3. RESILIENCE AND MEASUREMENTS

A first measurement of resilience, related to the ability of a material to recover from a shock, has been given in Charpy impact test. (Hollnagel and Woods, 2006) argue that resilience itself cannot be measured; only the potential for resilience can be. There is currently no objective measurement for assessing the resilience of a HMS but several different methods have been proposed in the literature.

#### 3.1 Measurements

(Martin, 2005) evaluates the resilience by maximum intensity of an absorbable force by the system without perturbing its functioning. For (Luo and Yang, 2002), the measurement of the instantaneous resilience is linked with the speed of recovery from a disturbance. Both of them do not consider the total time of disturbance which is an important requirement according to the definition of resilience.

(Orwin and Wardle, 2004) link resilience with the measurement of the instantaneous and maximal disturbance. (Pérez-España and Arreguín-Sánchez, 2001) calculate the resilience by the opposite of the tangent of the result of ratio between resistance and the recovery time of a disturbance. These measurements are related to a minimum acceptable performance threshold based and defined by designers and/or users of the system. As disturbances can lead to change system functioning goals, measurements cannot be assessed this way over the time.

We propose to define the principles of benefit-Cost-Deficit model (Vanderhaegen, 2004; Vanderhaegen et al., 2009) that could be used as an approach to characterise the HMS resilience.

#### 3.2 BCD model principles

The BCD model is based on indicators that assess the consequences of deviated human behaviours on several criteria related to technical or human performances or states. Positive consequences are Benefits and negative ones are acceptable Costs when the undesirable events are under control or Deficits when they are over control.

The logical value of functions B, C and D for an evaluation criterion when it is subjective or qualitative can be turned into a numeric value or an objective function by the following expression (1):

$$K_{J,i}(a,b) = s_i(b(t_b)) - s_i(a(t_a))$$

$$K_{J,i}(a,b) = \begin{cases} K_{B,i}(a,b) & \text{if } B_i(a,b) \\ K_{C,i}(a,b) & \text{if } C_i(a,b) \\ K_{D,i}(a,b) & \text{if } D_i(a,b) \\ 0 & \text{otherwise} \end{cases} \quad (1)$$

Where (Gu et al., 2009):

- $a$  and  $b$  are situations at times  $t_a$  and  $t_b$  respectively,
- $s_i(x(t_x))$  is the severity criterion associated to the position  $x$  at time  $t_x$ .

### 3.3 Application to the COR&GEST platform

The COR&GEST platform is a railway simulation platform developed in the University of Valenciennes. It involves a miniature railway structure on which several trains can move. The platform has a supervision interface to manage remotely signals and devices, and a driving interface for each train, both illustrates in Fig. 4.

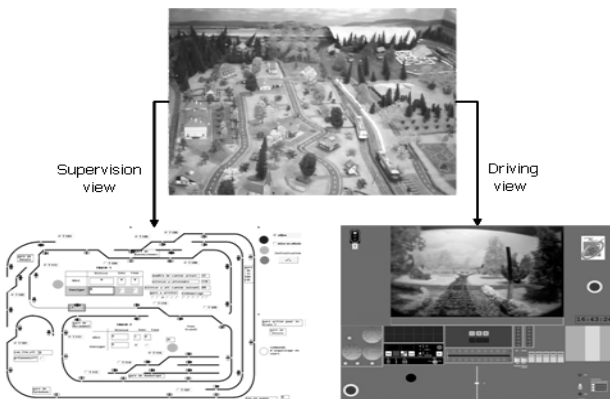

Fig. 4. The supervision and driving interfaces of the COR&GEST platform.

Trains transmit videos from miniature cameras to the driving interface. So, human operators can drive the miniature trains using several indicators such as the train

speed, the speed limit and signals that are virtually integrated into the view recorded from the cameras. The traffic is managed by the supervision interface completed by a scenario working station that allow building schedules and managing technical failure occurrences.

In order to study the human behaviour during the train driving activities with or without any technical failure occurrence, an experimental protocol was built with 7 inexperienced human operators. After a training phase for driving familiarisation on the platform, the human operators have to control a set of scenarios during 2 hours for two separates operational conditions:

- Without any disturbance, *i.e.* in normal conditions, to study the capacity of the operator to maintain the stability of the system in routine driving conditions;
- With disturbances to study respect of rules and procedures by human operators after an unplanned or sudden disturbance occurrence such as a break default, a temporary speed limitation, etc.

Then several performance criteria are assessed:

- The traffic safety in terms of barriers non violation, *i.e.* signals and speed limits respect,
- The departure quality related to the respect of trains departure time from stations,
- The arrival quality related to the respect of trains arrival time at stations,
- The human workload linked to the number of interactions between drivers and technical driving support systems.

The traffic safety criterion is considered as a potential deficit, benefits and costs are related to others criteria. Results, illustrated in Table 1, allow concluding that monotonous and repetitive tasks during a long time period can lead to a system performance decrement regarding BCD model parameters without disturbance. Furthermore, the failure occurrence can (Vanderhaegen, 2009b):

- Cause a breakdown in monotonous activity,
- Increase the situation awareness,
- Improve the control of several performance or safety criteria.

Table 1. Quantitative assessment of the BCD model parameters (negative values: costs or deficits; positive values: benefits).

	without disturbance				with disturbance			
	safety	Departure delay	Arrival delay	Interaction number	safety	Departure delay	Arrival delay	Interaction number
Human operator 1	-406	379	-103	-948	-401	-10	-161	-1058
Human operator 2	-24	397	-83	-666	-328	196	-168	-818
Human operator 3	-653	-160	-70	-902	-76	450	-179	-861
Human operator 4	-168	340	-260	-391	-423	740	-325	-688
Human operator 5	-167	71	-76	-674	-185	273	-159	-527
Human operator 6	-610	407	-114	-800	-176	290	-216	-867
Human operator 7	-21	257	-80	-724	-157	192	173	-775
Average	-293	242	-112	-729	-249	305	-148	-799

## 4. RESILIENCE AND LEARNING

### 4.1 Learning Process

A resilient HMS must be able to react and recover from unplanned events. In order to enhance his “resilience”, the system has to carry out learning process (Vanderhaegen et al., 2009) from reactions (successes and failures) through different methods such as:

- Observation of behaviour or actions,
- Imitation or copy of response’s actions to an event (Calinon, 2007),
- Groping or Trial-and-Error testing,
- Intuition, without reasoning.

Machine learning, inspired by related psychological theory, is the process of acquiring knowledge, skills and attitudes by modelling (Observation, Imitation) or by action (Groping, Intuition). It improves the system performance within resources and skills available (Buche, 2002).

In engineering context, we are interested in the learning processes which are classified into two approaches.

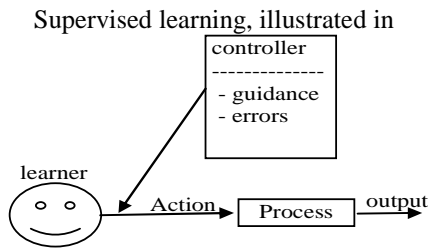

Fig. 5, where the supervised learner is “led” by a controller which provides guidance on actions to be performed in order to improve its performances. In the opposite, an unsupervised learner must discover by himself.

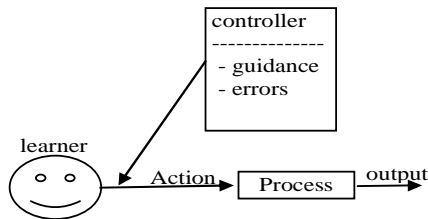

Fig. 5. Supervised learning (adapted from Buche, 2002).

### Reinforcement learning, illustrated in

Fig. 6, where the reinforcement learning agent dynamically interacts with the environment. With evaluative feedback passing back from the environment, a value function is formulated to guide the action towards the desired goal (Quah and al., 2005).

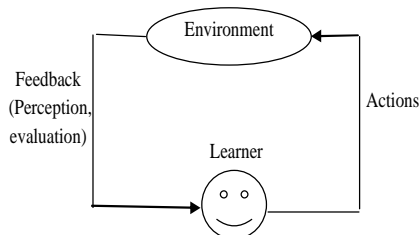

Fig. 6. Reinforcement learning (adapted from Kazuo, 2000).

For a HMS involved into an unexpected or unplanned disruption, reinforcement learning appears to be more adapted. Under uncertainty, the system interacts with environment to search for optimal decision-making behaviour. Thus reinforcement learning pursues a twofold objective:

- Lead optimally a system under pressure (optimal control in automatics),
- Learn or re-learn the optimal control through experiments (trial-error’s method).

### 4.2 Feedback/Feedforward control model

In order to be in control, a system must necessary know what has happened, *e.g.* with feedback control, what happens, by diagnostics, and what may happen, *e.g.* with feedforward control. The objective is to provide the required qualities, illustrated previously in Fig. 3, for the HMS. A great number of research works have proposed feedback and/or feedforward controllers using different methods in order to reach the mentioned objectives.

(Lee et al., 2000) have proposed a feedback/feedforward control structure, illustrated in Fig. 7, for the trajectory tracking of a linear DC (Direct Current) motor. The control model uses a conventional PID (Proportional Integral Derivative) feedback control to stabilise the system and a feedforward control using an iterative learning control (ILC) algorithm to enhance the tracking trajectories performances by capitalising on the experience gathered from the repeated execution of the same operations.

PID controller is the most common general-purpose controller using a feedback control mechanism. The proportional term handles the present state of the system, the integral term handles its past, and the derivative term tries to predict and handle the future. Feedforward refers to perception or anticipation; so feedforward control can be linked to learned anticipatory responses to known causes.

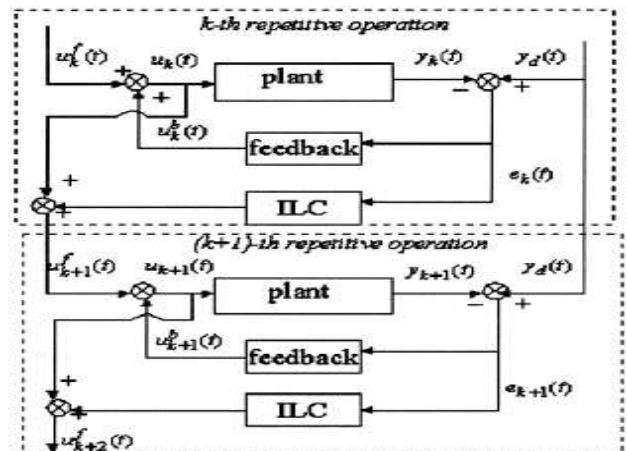

Fig. 7. Block diagram of Iterative Learning Control (from Lee et al., 2000).

(Jang et al, 1995) proposed an ILC model through feedback/feedforward structure, illustrated in Fig. 8, for

sharp tracking control of a manipulator robot. Feedback configuration ensures learning and feedforward is used for prediction. Feedforward controller is based on the rules updated by previous trial from the plant.

Therefore, the Feedback-Feedforward control model aims to provide the required qualities, illustrated in Fig. 3, for HMS resilience.

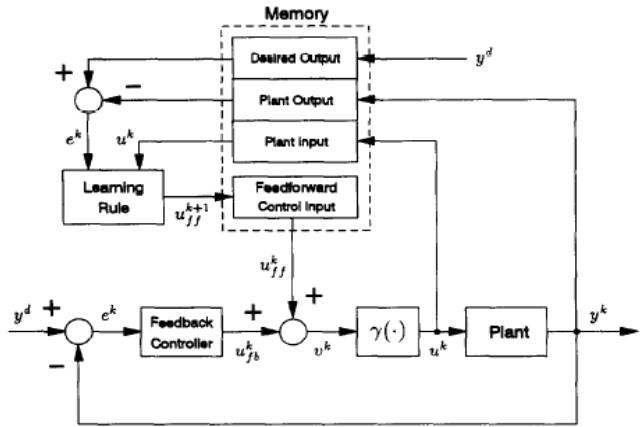

Fig. 8. Learning model with feedback/feedforward structure (from Jang et al, 1995).

#### 4.3 Behaviour in response to unexpected events

Facing unexpected events, a resilient HMS can react and overcome an issue applying one of the two behavioural approaches illustrated in Fig. 9.

In the first approach, we can first consider the current state can be identified by experience when system faces a known situation. Thus, a prognosis on the future states of the system can be determined *e.g.* by feedforward control, which is to assess or predict the future states based on the current state and various parameters of HMS. If the current state cannot be identify, in case of unforeseen event, or a prognosis not possible, a diagnosis will be performed *e.g.* by feedback control related to the previous states of the system in order to assess current one.

To sum up, if the current state of the HMS can be identify or assess by diagnosis, then a prognosis related to the reachable future states is done in order to select appropriate alternative or reaction to recover from

disruption. Resilience on known situations is then characterised.

The second approach focuses on the occurrence of a new or unprecedented situation. In this case, identification, prognosis and diagnosis are not possible. A trial and error action without knowing consequences on the HMS, like in reinforcement learning, must be realised. Actions can be performed iteratively (Vanderhaegen et al., 2009) for repetitive systems tasks, by experience or through a feedback/feedforward control model. Resilience improvement under unforeseen situations can be studied considering this approach.

The purpose of the algorithm illustrated in Fig. 9 is to achieve the selection of the most appropriate alternative and to define a new action plan with its associated consequences that will be applied to HMS in order to evaluate its impact in terms of resilience.

### 5. CONCLUSIONS

In this paper, we propose to analyse the resilience of Human-Machine Systems (HMS) in order to assess the potential resilience of systems and to improve it. A State of the Art on resilience and an adopted definition for HMS are given. Then, we presented some structures and methods for the improvement of system resilience. We also give a few indicators in literature used to measure system resilience. The BCD model is presented and applied on the COR&GEST rail simulation platform to analyse human activities.

In future works, we may use BCD model to define an efficient indicator for the assessment of HMS resilience.

### 6. ACKNOWLEDGMENTS

The present research work has been supported: By International Campus on Safety and Intermodality in Transportation, The Nord-Pas-de-Calais Region, The European Community, The Regional Delegation for Research and Technology, The Ministry of Higher Education and Research, And the National Center for Scientific Research. The authors gratefully acknowledge the support of these institutions.

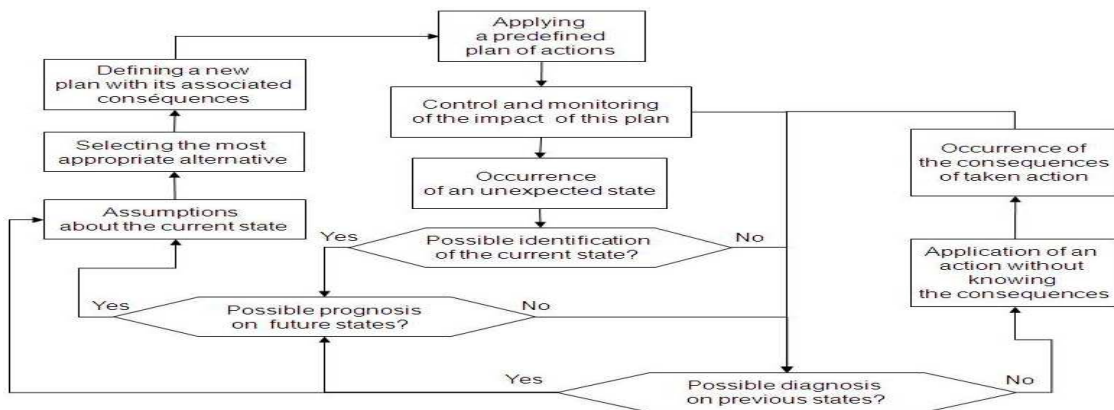

Fig. 9. Behaviour in response to unexpected events (adapted from Vanderhaegen, 2009a).

## REFERENCES

- Amalberti R. (2006). Violations et migrations ordinaires dans les activités à risques: conséquences pour la résilience globale et la gestion du retour d'expériences en entreprise. *ERGO'IA*, Biarritz, France.
- Buche C. (2002). Apprentissage par imitation pour les comportements d'agents autonomes. Rapport de DEA, Ecole Nationale d'Ingénieurs de Brest (ENIB),.
- Calinon S., Guenter F. and Billard A. (2007). On Learning, Representing, and Generalizing a task in a Humanoid Robot. *IEEE Transactions on Systems, Man, and Cybernetics – Part B: Cybernetics*, 37, 2.
- Charpy G. (1901). Note sur l'essai des métaux à la flexion par choc de barreaux entaillés, *Mémoire et compte-rendus de la Société des ingénieurs civils de France*.
- Chen C.-M., Lin C.-W., Chen Y.-C. (2007) Adaptive error-resilience transcoding using prioritized intra-refresh for video multicast over wireless networks. *Signal Processing: Image and Communication*, volume 22, 277-297.
- Cheveau F.-R., Wybo J.-L., (2007). Approche pratique de la culture de sécurité : pour une maîtrise des risques industriels plus efficace. *Revue Française de Gestion* 174, pp. 171-198.
- Goussé V. (2005). Apport de la génétique dans les études sur la résilience : l'exemple de l'autisme. *Annales Médico-Psychologiques*, Sous presse.
- Gu L., Enjalbert S., Vanderhaegen F. (2009). Human-machine systems resilience – Safety application. EAM 2009, 28th European Annual Conference on Human Decision Making and Manual Control, Reims, France, Septembre.
- Hollnagel E. (2006). Achieving system safety by resilience engineering. *1st Institution of Engineering and Technology International Conference on System Safety*.
- Hollnagel E., Woods D.D. (2006). Epilogue : Resilience engineering precepts. In E. Hollnagel, D.D. Woods, N. Leveson (Eds) *Resilience engineering : concepts and Precepts* Ashgate.
- Jacobs J.A., Kilduff T.F. (2005). Engineering Materials Technology (5th ed.). *Pearson Prentice Hall*. pp. 153–155.
- Jang, T.J., Choi, C.H. and Ahn, H.S.. (1995). Iterative Learning Control in Feedback Systems. *Automatica* Vol. 31, No.2, pp. 243-248.
- Kazuo, M. (2000). Learning scheduling control knowledge through reinforcements. *International Transactions in Operational Research* 7. pp125-138.
- Lee T.H., Tan K.K., Lim S.Y., Dou H.F. (2000). Iterative learning control of permanent magnet linear motor with relay automatic tuning. *Mechatronics* 10 169-190.
- Ludwig D., Walker B., Holling C.S. (1997). Sustainability, stability and resilience. *Conservation Ecology*, Vol. 1, N° 1, Art. 7.
- Luo M.-Y., Yang C.-S. (2002). Enabling fault resilience for web services. *Computer Communications*, 25 198-209.
- Marcantoni W.S., (2009). Mécanismes cellulaires de l'apprentissage. <http://www.unites.uqam.ca/cnc/psy4042/mecanismesneuronaux.pdf>
- Martin S. (2005). La résilience dans les modèles de systèmes écologiques et sociaux. Thèse de doctorat, Ecole Normale Supérieure de Cachan, France.
- Nakayama H., Ansari N., Jamalipour A., Kato N., (2007) Fault-resilient sensing in wireless sensor networks. *Computer Communication*, 30, 2375-2384.
- Numanoglu T., Tavli B., Heinzelman W., (2006) Energy efficiency and error resilience in coordinated and non-coordinated medium access control protocols. *Computer Communications*, 29, 3493-3506.
- Orwin K. H., Wardle D. A., (2004). New indices for quantifying the resistance and resilience of soil biota to exogenous disturbances. *Soil Biology & Biochemistry*, 36 1907-1912.
- Pérez-España H., Sánchez A., (2001). An inverse relationship between stability and maturity in models of aquatic ecosystems. *Ecological Modelling*, 145 189-196.
- Quah K.H, Quek C., Leedman G., (2005). Reinforcement learning combined with a fuzzy adaptive learning control network (FALCON-R) for pattern classification. *Pattern Recognition*, 38 513–526.
- Vanderhaegen F., (2004). The benefit-cost-deficit (BCD) model for human analysis and control. *Proceedings of the Ninth IFAC/IFORS/IEA Symposium on Analysis, Design, and Evaluation of Human-Machine Systems*, Atlanta, GA, USA,.
- Vanderhaegen F., (2009a). Pronostic, diagnostic et tâtonnement face à des situations dynamiques, LAMIH internal review.
- Vanderhaegen, F. (2009b). Rail simulation to study human reliability. *Proceedings of the 3rd international conference on Rail Human Factors*, Lille, France.
- Vanderhaegen F., Polet P., Zieba S., (2009). A reinforced iterative formalism to learn from human errors and uncertainty. *Engineering Applications and Artificial Intelligence*, 22, 654-659.
- Wreathall J. (2006). Properties of resilient organisations: An initial view. In E. Hollnagel, D. Woods and N. Leveson (Eds.): *Resilience engineering: Concepts and precepts*. Aldershot, UK: Ashgate.
- Zieba S., Jouglet D., Polet P., Vanderhaegen F., (2007). Resilience and affordances: perspectives for human-robot cooperation? Paper presented at the 26th European Annual Conference on Human Decision Making and Manual Control, Copenhagen, Denmark.